

POSHTECH

**A Perfect Solution for
Efficient Cutting**

SCF SERIES **CNC DOUBLE COLUMN MACHINING CENTER**

JEOU YANG MACHINERY CO., LTD
NO. 197, MIN-SHENG ST., TAN-TZU
TAICHUNG, TAIWAN, ROC.
TEL: +886-4-2537-0971
FAX: +886-4-2537-0984

AGENT/代理商

SCF SERIES *(Small Model)*

CNC DOUBLE COLUMN MACHINING CENTER

- Range of X-axis travel: **2200~3200mm.**
- Two linear guide ways on base (X-axis).
- Two linear guide ways on Y-axis with two blocks on each linear guide way.
- Box ways on Z-axis.
- Both columns and the cross beam cast in one single piece.
- BT50, 6000rpm gear-drive spindle.



SCF SERIES *(Two Linear Guide Ways on X-axis)*

CNC DOUBLE COLUMN MACHINING CENTER

- Range of X-axis travel: **2200~5200mm.**
- Two linear guide ways on base (X-axis).
- Two linear guide ways on Y-axis with three blocks on each linear guide way.
- Box ways on Z-axis.
- Step type beam construction.
- BT50, 4000rpm gear-drive spindle.



SCF SERIES *(Three Linear Guide Ways on X-axis)*

CNC DOUBLE COLUMN MACHINING CENTER

- Range of X-axis travel: **4200~7200mm**.
- Three linear guide ways on base (X-axis).
- Two linear guide ways on Y-axis with three blocks on each linear guide way.
- Box ways on Z-axis.
- Step type beam construction.
- BT50, 4000rpm gear-drive spindle.



Get Exceptional Rigidity And Stability with Best Structure Design

Step type linear guide ways layout.
Three blocks on each linear guide way.

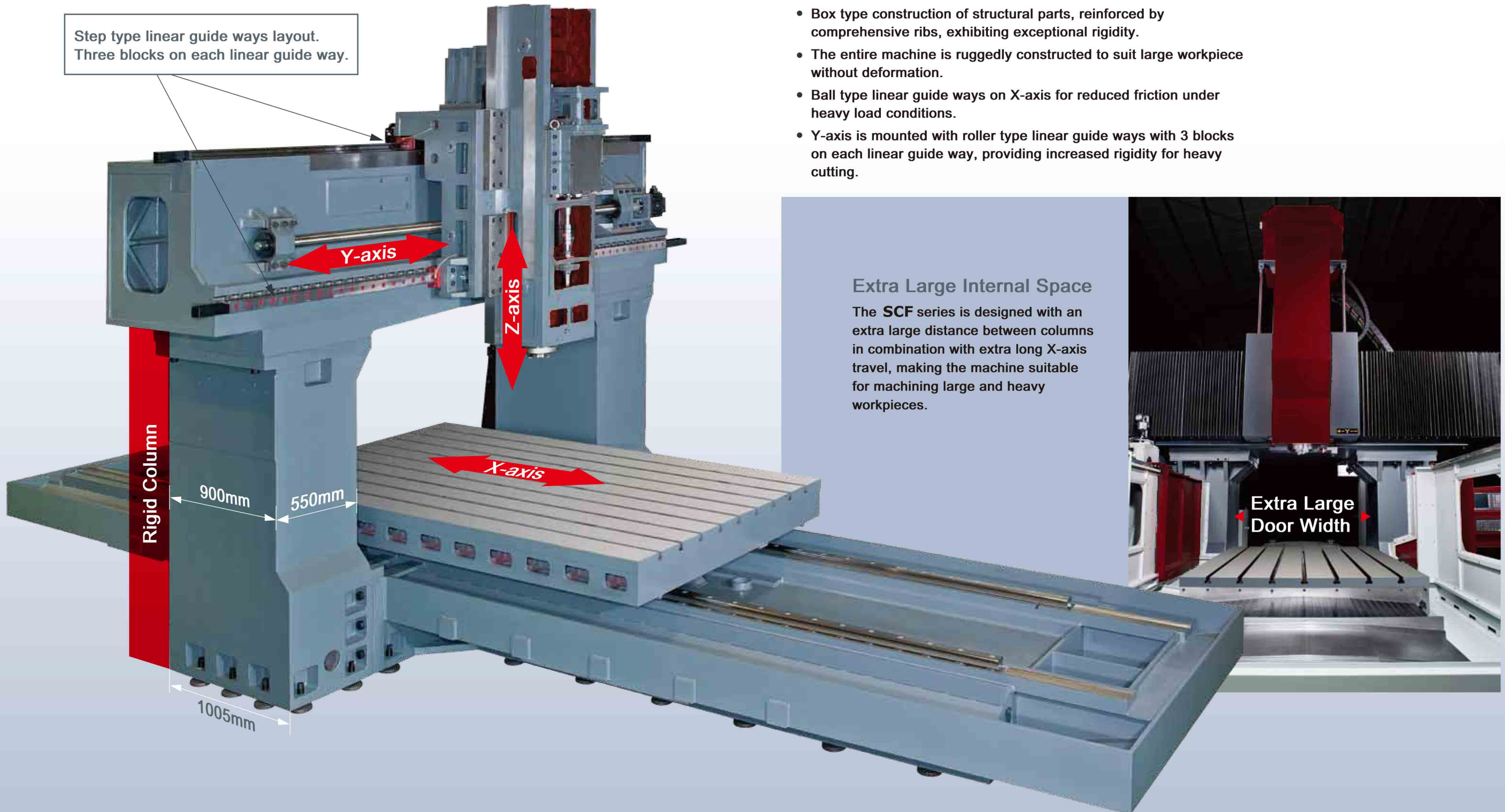

- All structural parts are manufactured from MEEHANITE cast iron, tempered and stress relieved for deformation-free structure and long-term accuracy.
- Box type construction of structural parts, reinforced by comprehensive ribs, exhibiting exceptional rigidity.
- The entire machine is ruggedly constructed to suit large workpiece without deformation.
- Ball type linear guide ways on X-axis for reduced friction under heavy load conditions.
- Y-axis is mounted with roller type linear guide ways with 3 blocks on each linear guide way, providing increased rigidity for heavy cutting.

Extra Large Internal Space

The **SCF** series is designed with an extra large distance between columns in combination with extra long X-axis travel, making the machine suitable for machining large and heavy workpieces.

Extra Large
Door Width

Step Type Beam for Improved Cutting Stability

The oversized beam is a step type construction, that allows for better stability of cutting.



Scientifically Rib Reinforced Beam

The oversized beam in combination with scientific rib reinforcement in the beam interior helps to maximize structural rigidity, and provide a solid support for the spindle head.



65mm Roller Type Linear Guide Ways on Column (Y-axis)

The Y-axis is mounted with 65mm roller type linear guide ways. Each linear guide way (upper and lower) is equipped with three blocks respectively for increased rigidity of the spindle head.



Hydraulic Counter-balance on Z-axis

The Z-axis movement is counter-balanced by two hydraulic cylinders, ensuring outstanding smoothness and stability of Z-axis movement.



Accumulator

The accumulator is used to supply pressure source to the hydraulic cylinders, allowing the Z-axis to move smoothly.



Directly Coupled To Ball Screw

The servo motor on the Y-axis is directly coupled to the ball screw with a coupling, that eliminates backlash while achieving high transmission accuracy.



HEIDENHAIN Linear Scales (Optional)

Linear scales for high positioning accuracy are available for the X, Y and Z-axis.



Two Linear Guide Ways on The Base (X-axis)

- The base on models with a door width of 1600/2100/2600mm are mounted with two linear guide ways. In addition, the highly rigid table with a thickness of up to 250mm combined with two-layer rib reinforcement to ensure no deformation even under heavy load conditions.
- The X-axis is mounted with 65mm ball type linear guide ways, featuring low friction and making it ideal for heavy workpiece machining.

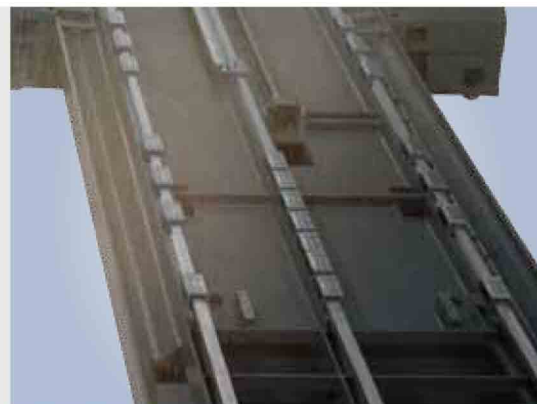

Three Linear Guide Ways on The Base (X-axis)

- The base on models with a door width of 2800/3200/3600mm are mounted with three linear guide ways. In addition, the highly rigid table with a thickness of up to 320mm combined with two-layer rib reinforcement to ensure no deformation even under heavy load conditions.
- The X-axis is mounted with 65mm ball type linear guide ways, featuring low friction and making it ideal for heavy workpiece machining.



Two Chip Augers on Base

The right and left side of base are equipped with two chip augers for delivering chips to the front mounted link chain type chip conveyor. These chip augers enable the machine to keep clean during cutting.



Chip Conveyor

The front mounted link chain type chip conveyor collects the chips from the chip augers for delivering chips out of the machine.

Big Capacity

- The coolant tank can be moved out for convenient cleaning.
- Upon request, an oil coolant separation device is available to prevent cutting fluid from deterioration. (Optional)

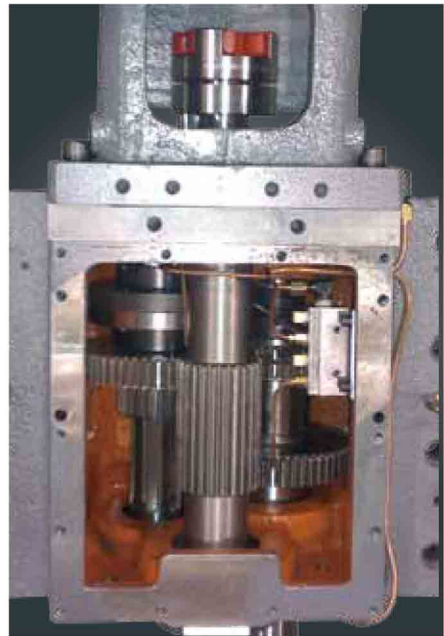

Gearbox Type Spindle Head

The Ø100mm spindle is driven by a α 22 spindle motor and transmitted through a gearbox, providing maximum speed 6000rpm and 755N-m of torque output. This makes the machine ideal for both high speed and heavy cutting applications. When a 4000rpm is used, torque output may reach 1132N-m for extra powerful cutting operation.

Optional Accessories

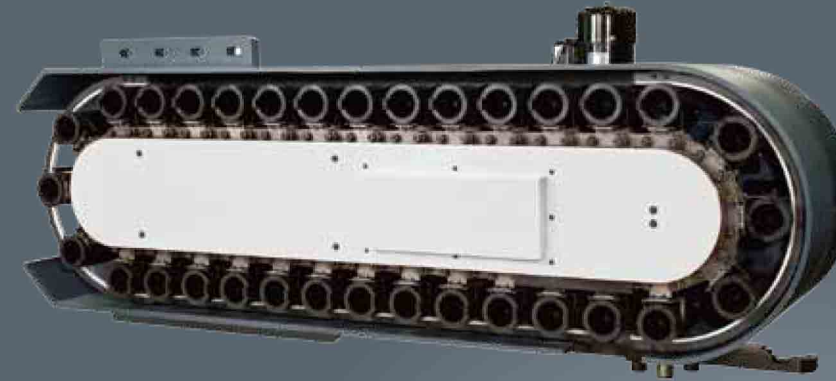

Side-mount Chain Type Magazine

- A choice of 32, 40 or 60 tools is available.



Disk Type Magazine

- Load capacity is 24 tools.

Spindle Speed / Torque Diagram

FANUC A15 / 7000

SCF series

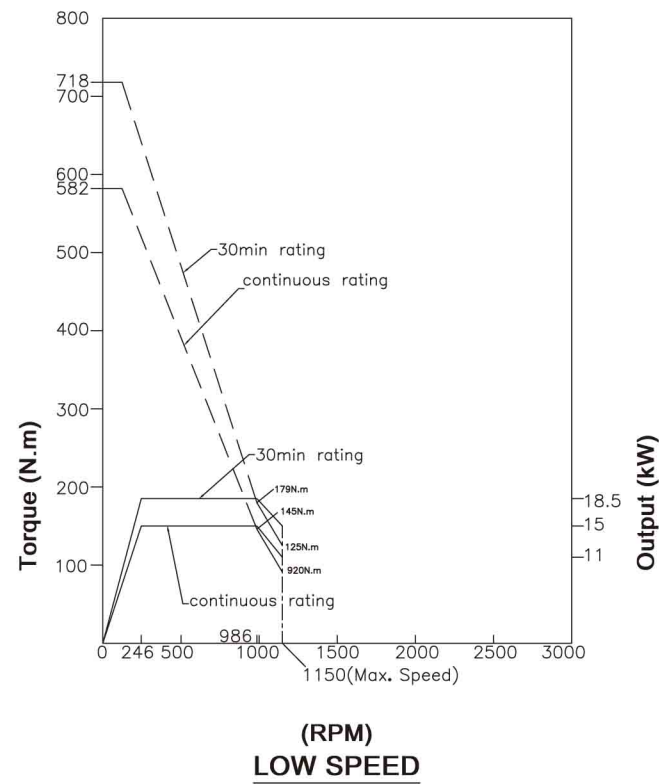
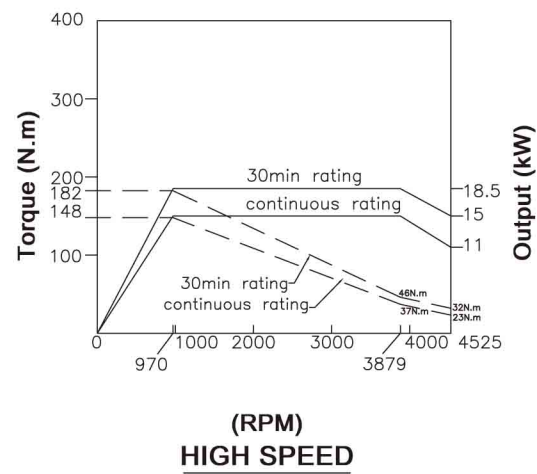

Work Piece Coordinate Measuring (OMP 60)



Auto. Tool Length & Diameter Measurement (TS-27R)

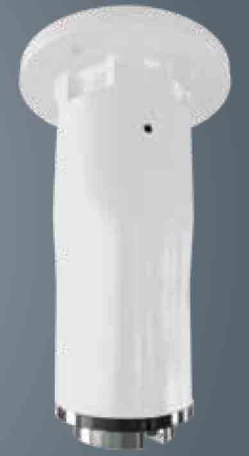

Extension Head



Manual Universal Milling Head (A type)



Manual Universal Milling Head (B type)



CNC Rotary Table



Tailstock

SCF SERIES

CNC Double Column Machining Center (Small Model)

MACHINE SPECIFICATIONS

UDM-XXXX A [x100mm]: X-Axis Travel B [x100mm]: Y-Axis Travel []: As Optional

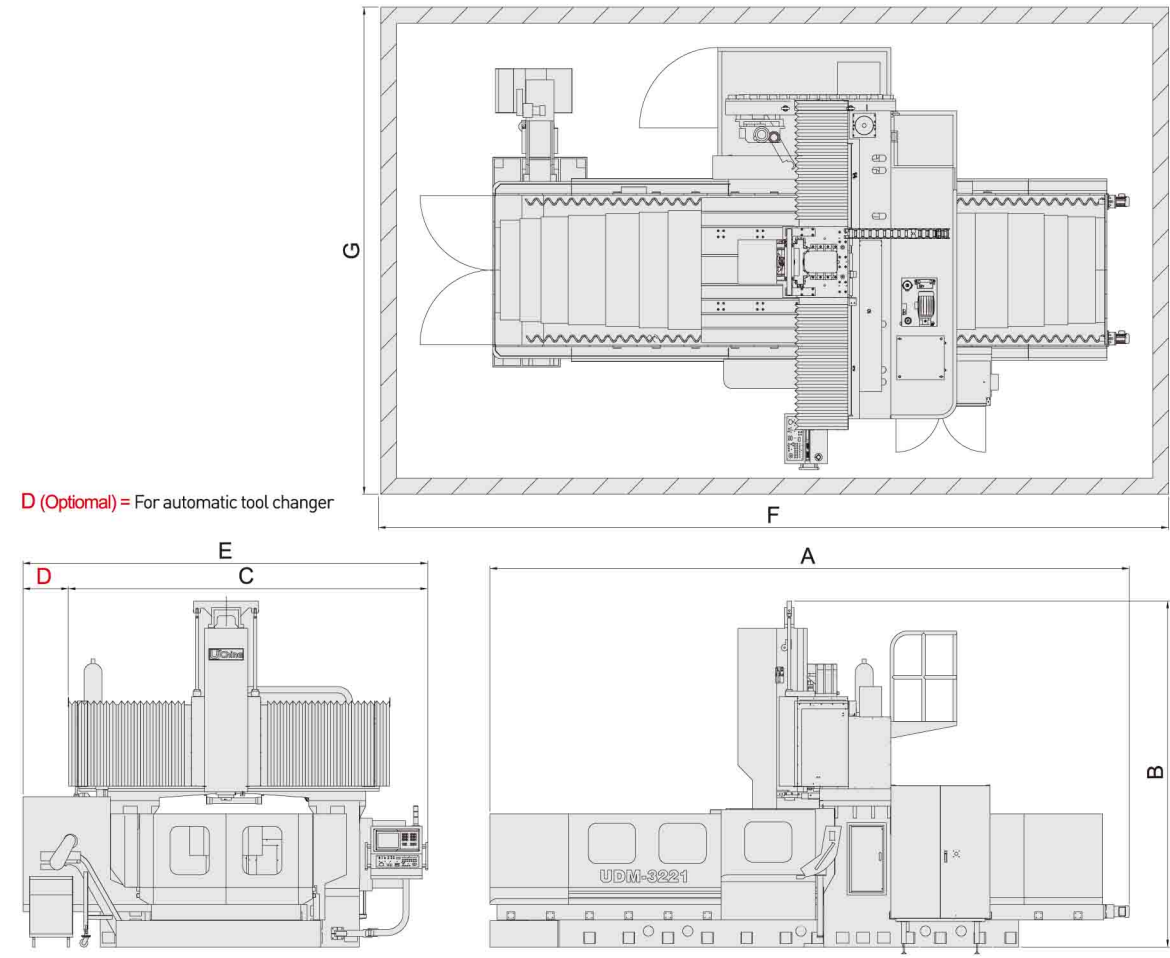

D (Optional) = For automatic tool changer

Unit: mm

	MODEL	A	B	C	D	E	F	G
2 linear guide ways(X-axis)	SCF-2216	6280	4400	4080	570	4650	8280	6650
	SCF-3216	8280	4400	4080	570	4650	10280	6650
	SCF-4216	10280	4400	4080	570	4650	12280	6650
	SCF-2221	6280	4400	4580	570	5150	8280	7150
	SCF-3221	8280	4400	4580	570	5150	10280	7150
	SCF-4221	10280	4400	4580	570	5150	12280	7150
	SCF-5221	12280	4400	4580	570	5150	14280	7150
	SCF-3226	8280	4400	5080	570	5650	10280	7650
	SCF-4226	10280	4400	5080	570	5650	12280	7650
	SCF-5226	12280	4400	5080	570	5650	14280	7650
3 linear guide ways(X-axis)	SCF-4228	11100	4600	5420	420	5840	13100	7840
	SCF-5228	13300	4600	5420	420	5840	15300	7840
	SCF-6228	15500	4600	5420	420	5840	17500	7840
	SCF-4232	11100	4600	5820	420	6240	13100	8240
	SCF-5232	13300	4600	5820	420	6240	15300	8240
	SCF-6232	15500	4600	5820	420	6240	17500	8240
	SCF-7232	16900	4600	5820	420	6240	18900	8240
	SCF-4236	11100	4600	6220	420	6640	13100	8640
	SCF-5236	13300	4600	6220	420	6640	15300	8640
	SCF-6236	15500	4600	6220	420	6640	17500	8640
SCF-7236	16900	4600	6220	420	6640	18900	8640	

■ Specifications are subject to change without prior notice.

	MODEL	UNIT	SCF-2212	SCF-3212
TABLE	Table Size	mm	2000 x 1100	3000 x 1100
	T-slots Size	mm	22	
	Maximum Load	kg	3500	4500
TRAVEL	X-Axis	mm	2200	3200
	Y-Axis	mm	1200	
	Z-Axis	mm	760	
SPINDLE	Spindle Servo Motor - cont. / 30min.	kW	11/15 (22/26)	
	Speed	rpm	6000	
	Taper		7/24 Taper, ISO.50, BT-50	
DISTANCES	Between Two Columns	mm	1300	
	Spindle Nose to Table Surface	mm	200 ~ 960	
FEED RATE	Rapid Feed Rate X/Y/Z	m/min	20 / 20 / 15	
	Minimum Setting	mm/min	0.001	
	Cutting Feed Rate	m/min	8	
ATC	No. of Tools	pieces	0 (24 / 32 / 40)	
	Tool Change Time - T to T (approx.)	sec	8 (Arm Type)	
	Max. Tool-Diameter / Length	mm	Ø125/Ø200 (Without Adjacent Tool) / Length 350	
	Max. Tool Weight	kg	15	
COOLANT & LUBRICATION	Coolant Tank Volume	L	240	
	Hydraulic Tank Volume	L	70	
MISCELLANEOUS	Lubrication Tank Volume	L	8	
	Power Required	kVA	40	
	Pressurized Air	kg/cm ²	5 ~ 8	
	Hydraulics Required	kg/cm ²	70	
	Machine Weight (approx.)	kg	17000	21000
	Controller		FANUC Oi MD (FANUC 32i-B/31i-B) (MELDAS M70/M720/M730) (SIEMENS, HEIDENHAIN)	

■ Specifications are subject to change without prior notice.

STANDARD ACCESSORIES :

- Glass window type splash guard
- Programmable coolant system
- Automatic lubrication system
- Spindle air blast system
- Working lamp
- Alarm lamp for abnormal situations
- Indication lamp for dwell & end of job
- Leveling bolts & pads
- Chip auger & chain type chip conveyors
- Toolbox with spanners & wrenches
- M.P.G
- Machine inspection lists
- Operation manuals
- Controller manuals and circuit diagram
- Auto power off
- RS-232C terminal interface
- Spindle coolant system
- Hydraulic system
- Heat exchanger
- FANUC Oi MD Controller

OPTIONAL ACCESSORIES :

- 8000RPM direct drive spindle (35HP)
- X, Y and Z axes with linear scales
- Auto. tool length & diameter measurement (TS-27R)
- CNC rotary table
- ATC: 24, 32, 40 tools
- Coolant through spindle
- Oil-feed holder
- Oil mist device
- Air conditioner for electrical cabinet
- FANUC 32i-B (31i-B) Controller
- MELDAS (M70, M720, M730) Controller
- SIEMENS Controller
- HEIDENHAIN Controller
- 12000RPM or 15000RPM direct drive spindle-BBT 40 (only for FANUC or MELDAS controller)

MACHINE SPECIFICATIONS

[]: As Optional

MODLE		UNIT	SCF-2216	SCF-2616	SCF-3216	SCF-4216	SCF-2221	SCF-3221	SCF-4221	SCF-5221	SCF-3226	SCF-4226	SCF-5226
TABLE	Table Size	mm	2000x1400	2400x1400	3000x1400	4000x1400	2000x1800	3000x1800	4000x1800	5000x1800	3000x2200	4000x2200	5000x2200
	T-slots Size	mm	22										
	Maximum Load	tons	6	8	9	10	8	10	12	15	12	14	18
TRAVEL	X-Axis	mm	2200	2600	3200	4200	2200	3200	4200	5200	3200	4200	5200
	Y-Axis	mm	1600			2100				2600			
	Z-Axis	mm	800 (1000, 1200)										
SPINDLE	Spindle Servo Motor - cont. / 30min.	kW	15/18.5 (22/26)										
	Speed	rpm	4000 (6000)										
	Taper		7/24 Taper ISO.50, BT-50										
DISTANCES	Between Two Columns	mm	1600			2100				2600			
	Spindle Nose to Table Surface	mm	200~1000 (200~1200, 200~1400)										
FEED RATE	Rapid Feed Rate X/Y/Z	m/min	12 / 12 / 10										
	Minimum Setting	mm/min	0.001										
	Cutting Feed Rate	mm/min	1~5000										
ATC	No. of Tools	pieces	[24 / 32 / 40 / 60]										
	Tool Change Time - T to T (approx.)	sec	8 (Arm Type)										
	Max. Tool-Diameter / Length	mm	Ø125/Ø200 (Without Adjacent Tool) / Length 350										
	Max. Tool Weight	kg	18										
COOLANT & LUBRICATION	Coolant Tank Volume	L	450			640				680			
	Hydraulic Tank Volume	L	70			80							
	Lubrication Tank Volume	L	8										
MISCELLANEOUS	Power Required	kVA	50										
	Pressurized Air	kg/cm ²	7										
	Hydraulics Required	kg/cm ²	70										
	Machine Weight (approx.)	tons	23	25	27	32	27	29.5	35	38.5	38.5	43	49
Controller		FANUC 32i-B (31i-B) (MELDAS M70/M720/M730) (SIEMENS, HEIDENHAIN)											

■ Specifications are subject to change without prior notice.

STANDARD ACCESSORIES :

- Glass window type splash guard
- Programmable coolant system
- Automatic lubrication system
- Spindle air blast system
- Work lamp
- Alarm lamp for abnormal situations
- Indication lamp for dwell & end of job
- Leveling bolts & pads
- Chip auger & chain type chip conveyor
- Toolbox with spanners & wrenches
- M.P.G
- Machine inspection lists
- Operation manuals
- Controller manuals and circuit diagram
- Auto power off
- RS-232C terminal interface
- Spindle coolant system
- Hydraulic system
- Heat exchanger
- FANUC 32i-B Controller

OPTIONAL ACCESSORIES :

- Auxiliary work table
- CNC rotary table
- ATC: 24, 32, 40, 60 tools
- Auto. tool length & diameter measurement (TS-27R)
- Work piece coordinate measuring (OMP 60)
- Various milling heads are available
- Linear scales
- Coolant through spindle
- Oil-feed holder
- Oil mist device
- Programmable coolant nozzle
- Air conditioner for electrical cabinet
- Auto heat compensation

MACHINE SPECIFICATIONS

[]: As Optional

MODLE		UNIT	SCF-4228	SCF-5228	SCF-6228	SCF-4232	SCF-5232	SCF-6232	SCF-7232	SCF-4236	SCF-5236	SCF-6236	SCF-7236	
TABLE	Table Size	mm	4000x2500	5000x2500	6000x2500	4000x2900	5000x2900	6000x2900	6000x2900	4000x3000	5000x3000	6000x3000	6000x3000	
	T-slots Size	mm	22											
	Maximum Load	tons	16	20	24	16	20	24	24	16	20	24	24	
TRAVEL	X-Axis	mm	4200	5200	6200	4200	5200	6200	7200	4200	5200	6200	7200	
	Y-Axis	mm	3200			3600				4000				
	Z-Axis	mm	800 (1000, 1200)											
SPINDLE	Spindle Servo Motor - cont. / 30min.	kW	15/18.5 (22/26)											
	Speed	rpm	4000 (6000)											
	Taper		7/24 Taper ISO.50, BT-50											
DISTANCES	Between Two Columns	mm	2800			3200				3600				
	Spindle Nose to Table Surface	mm	200~1000 (200~1200, 200~1400)											
FEED RATE	Rapid Feed Rate X/Y/Z	m/min	10 / 12 / 10											
	Minimum Setting	mm/min	0.001											
	Cutting Feed Rate	mm/min	1~5000											
ATC	No. of Tools	pieces	[24 / 32 / 40 / 60]											
	Tool Change Time - T to T (approx.)	sec	8 (Arm Type)											
	Max. Tool-Diameter / Length	mm	Ø125/Ø200 (Without Adjacent Tool) / Length 350											
	Max. Tool Weight	kg	18											
COOLANT & LUBRICATION	Coolant Tank Volume	L	700								750			
	Hydraulic Tank Volume	L	80											
	Lubrication Tank Volume	L	8											
MISCELLANEOUS	Power Required	kVA	50											
	Pressurized Air	kg/cm ²	7											
	Hydraulics Required	kg/cm ²	70											
	Machine Weight (approx.)	tons	48	54	60	55	62	68	75	58	64	72	82	
Controller		FANUC 32i-B (31i-B) (MELDAS M70/M720/M730) (SIEMENS, HEIDENHAIN)												

■ Specifications are subject to change without prior notice.

STANDARD ACCESSORIES :

- Glass window type splash guard
- Programmable coolant system
- Automatic lubrication system
- Spindle air blast system
- Work lamp
- Alarm lamp for abnormal situations
- Indication lamp for dwell & end of job
- Leveling bolts & pads
- Chip auger & chain type chip conveyor
- Toolbox with spanners & wrenches
- M.P.G
- Machine inspection lists
- Operation manuals
- Controller manuals and circuit diagram
- Auto power off
- RS-232C terminal interface
- Spindle coolant system
- Hydraulic system
- Heat exchanger
- FANUC 32i-B Controller

OPTIONAL ACCESSORIES :

- Auxiliary work table
- CNC rotary table
- ATC: 24, 32, 40, 60 tools
- Auto. tool length & diameter measurement (TS-27R)
- Work piece coordinate measuring (OMP 60)
- Various milling heads are available
- Linear scales
- Coolant through spindle
- Oil-feed holder
- Oil mist device
- Programmable coolant nozzle
- Air conditioner for electrical cabinet
- Auto heat compensation